

Audio, Video and  
Communications  
for Broadcasters



# INTERCOM SYSTEMS

More than an Intercom:  
A Global Solution for Audio Communications

# Full Integration

Until Today, existing technology has forced customers to work with separate systems to manage audio and communications. They were normally completely separate systems that didn't allow for interoperability and to optimize through resource sharing.

The objective with this new generation of systems is to be able to offer complete integration. This will allow the user to share both hardware and software resources, simplify the operation and to control its productions based upon very stable, redundant systems, with the best available audio quality and possibility to extensively process the audio signals. State-of-the-art technology that provides connectivity to AoIP networks with centralized control. In a nutshell, a leap forward towards 360° management of all your contents in a simple way, making the achievement of the best possible final results and easy task.

In order to achieve this goal, we cannot forget about audio quality at any moment. That's why our systems process the audio signal with 48 KHz sampling rate and 24 bits resolution, providing a broadcast-quality flow between all our devices. One of the most important reasons that allows us to keep this quality level is the use of AoIP Dante™ / AES 67 standard for the audio transport between equipment.

AEQ's experience from providing solutions for large international events, experience acquired over a large number of years, allows us to have quite a clear idea about what is needed for very demanding productions in terms of quality, operations and reliability. Our new generation of audio systems is designed to satisfy our customers' needs by integrating those traits.

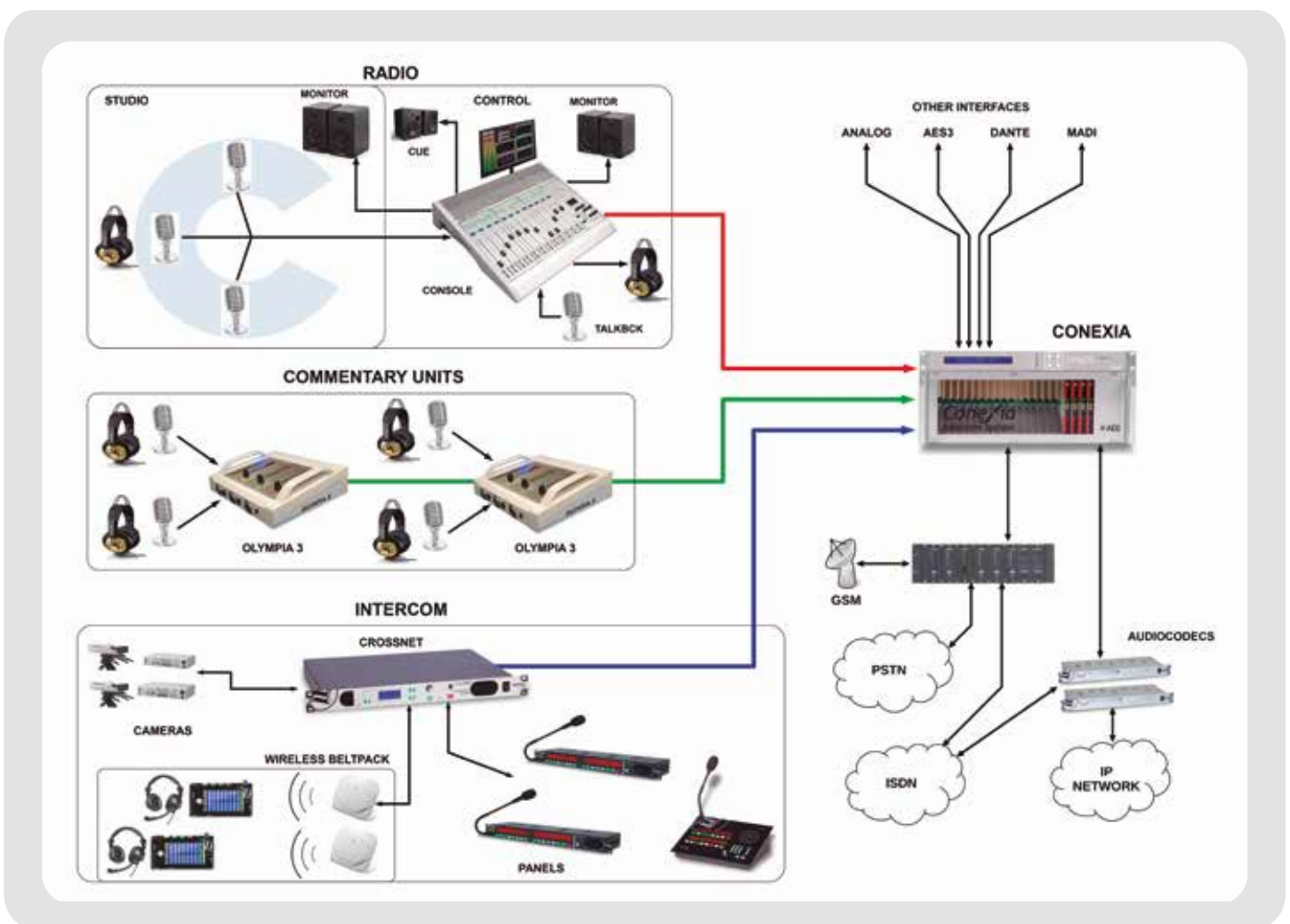



## CrossNET

**CrossNET** is a compact, integrated audio solution. It is an AoIP-based matrix, using Dante™ and compatible with AES 67, and is available in 1 RU height and with the capacity to manage up to 168x168 audio channels with broadcast-quality audio signal processing.

Thanks to its scalability, from 40 x 40 to 168 x168 channels, the system offers a range of external direct connections: analog and digital ports, AoIP Dante™ and KROMA Legacy low bit-rate VoIP. The integration of this variety of connections within the same unit allows the user to reduce the number of external equipment required.



The largest expression of the CrossNET Matrix is a 168 x 168 audio channels Intercom Matrix with the following port distribution:

- 12 four-wire, broadcast-quality, balanced analog audio ports for general purpose connections to external circuits such as audio consoles, I/O for PA, camera intercom or IFB's, etc.
- 8 digital audio ports (KROMA Legacy ports), providing backward compatibility with earlier KROMA systems, allowing the user to connect KROMA user panels from all series as well as interface cards.
- 20 low-bitrate KROMA Legacy VoIP audio ports that allow for the connection of remote user panels using narrow-band Internet connections, EasyNET party-line systems and, specially, the connection of Xplorer system for wireless belt packs and virtual panels.
- Up to 128 Dante™ broadcast-quality audio ports that may be used to connect TP8000-series user panels, our Olympia 3 Commentary System or maybe other compatible audio devices from more than 400 manufacturers using Dante™ and AES 67 standards.



### Scalable to each need

The CrossNET Matrix is available in the following versions:

#### CrossNET 40:

8 KROMA digital Intercom ports, 12 balanced broadcast quality analog audio ports and 20 ports for compressed audio over IP.

#### CrossNET 72:

32 Ports with Dante™ AoIP Interface, 8 KROMA digital Intercom ports, 12 balanced broadcast quality analog audio ports and 20 ports for compressed audio over IP.

#### CrossNET 104:

64 Ports with Dante™ AoIP Interface, 8 KROMA digital Intercom ports, 12 balanced broadcast quality analog audio ports and 20 ports for compressed audio over IP.

#### CrossNET 136:

96 Ports with Dante™ AoIP Interface, 8 KROMA digital Intercom ports, 12 balanced broadcast quality analog audio ports and 20 ports for compressed audio over IP.

#### CrossNET 168:

128 Ports with Dante™ AoIP Interface, 8 KROMA digital Intercom ports, 12 balanced broadcast quality analog audio ports and 20 ports for compressed audio over IP.

**Main system features:**

• **The matrix can be expanded following user's requirements.**

The system can be expanded by adding Dante™ IP expansion port cards, starting from any of the intermediate sizes of a CrossNET matrix.

• **Adjustable audio levels.**

CrossNET allows for independent input and output audio level control for each port, as well as for level control of the established crosspoints.

• **IFB's.**

The system offers several possibilities for IFB that are implemented by the matrix and configured through the Crossmapper Intercom Matrix Software. Modes range from complete interruption to different levels of audio signal attenuation.

• **PSTN / ISDN / GSM / VoIP / SIP calls.**

The matrix is able to directly manage calls and dialing for Public Switched Network Telephone Networks, ISDN, GSM, or SIP based VoIP calls using compatible AEQ audiocodescs, for both audio coordination and contribution. You only need to define the cards or devices as interfaces in the configuration.

• **Xplorer wireless system base station.**

The CrossNET matrix itself allows for the creation of an Xbp wireless-beltpack or Xvirtual virtual-panels infrastructure, by means of a 2.4 / 5 GHz WiFi managed access point network that can operate in roaming mode.

• **An integrated, small user panel.**

The front LCD screen, loudspeaker and micro-headphone input allows to use the proper Matrix as a small, 4-key user panel, which is always available to establish communications or monitor system audio channels where the matrix is installed.

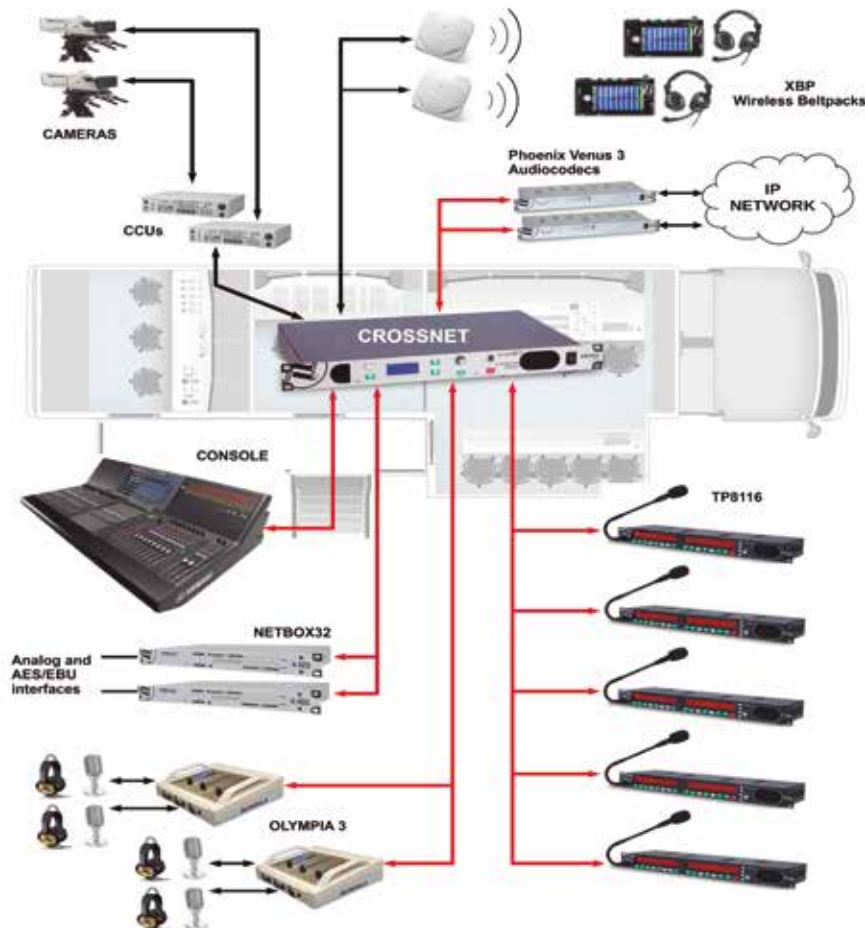





# Conexia

Conexia system can be defined as a truly global solution which is able to manage all of our audio communications and contributions. It is based on a broadcast matrix, and puts the widest selection of available audio formats at our disposal in a completely modular way, whereas the resources can be selected according to each system's particular requirements. At the same time, this modularity can provide total system redundancy, so system controllers, audio crosspoint/processing cards and even simple or Multichannel I/O cards can have automatic back-up. The internal TDM bus makes the matrix grow up to 1024 x 1024 ports. All these features build up a broadcast-quality system with 48 kHz sampling frequency and 24 bits resolution, with great robustness and flexibility to manage our audio and intercom system.



Conexia system structure is based on a 4U 19" rack that comprises three important blocks; at the front, the slots for the audio processing and communications crosspoints DSP cards are located. These tasks are performed dynamically, so backup cards for automatic function failover can be inserted.

On the other hand, there are another two types of slots at the back. Two of them are dedicated to the system controller card and another one for optional redundancy, and in the remaining 21 slots, input/output cards for the different required audio formats can be inserted.

There are a total of 20 slots of this kind that may be populated depending on the system size and requirements.

Last, there is an internal back-panel in the middle of the unit that acts as an interconnection and TDM-bus transmission media for the 1024 channels in the system.

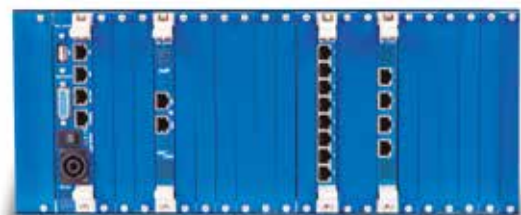

Conexia Master is a higher-level management system that allows for the control of the whole intercom layer, distributing the crosspoint orders according to the user-defined configuration map. Consistently with the system philosophy and robustness, two pieces of equipment can be connected simultaneously in "mirror" mode to provide inherent redundancy.



**100% REDUNDANT**

The integration of different systems, the large number of signals to manage, and the fact that communications are so critical during productions, demand that everything is covered in a system of this kind in order to avoid any unexpected issue. That's why ConeXia offers solutions which provide reliability to every requirement.

Ring diagram with redundant HSAL

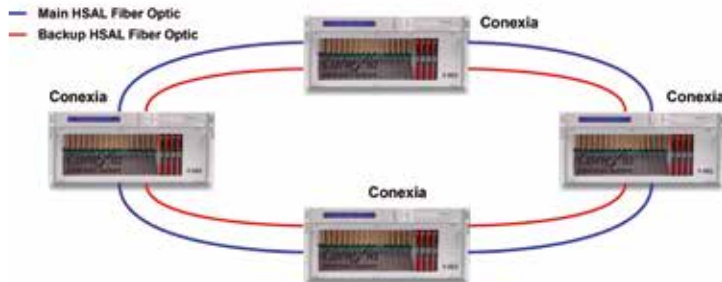

A large ConeXia-based installation can be deployed as a distributed system or as a pool of smaller matrixes operating as if they were a single one. This requires that the information flow between the different blocks is always present. ConeXia double-ring communication is the perfect solution, not only due to its inherent reliability, but also because it is possible to implement it using any of the Multichannel links included in the system.

Redundant diagram with multi-channel cards to console and matrix

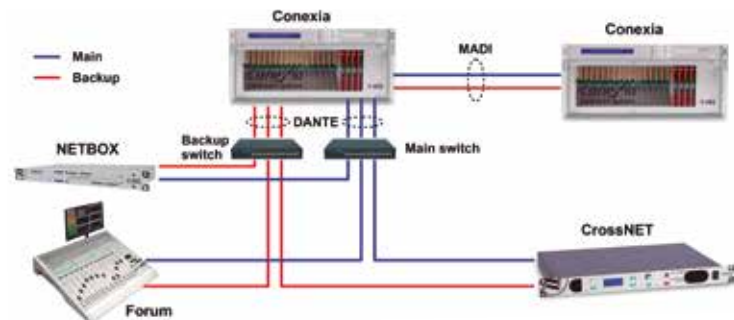

ConeXia is an open system allowing for the interconnection to other equipment using discrete or Multichannel audio links, with interfaces such as MADI or DANTE™, compatible with any other devices featuring these protocols. These communications can be made absolutely reliable as the system allows for redundant connections with automatic audio failover.

Diagram connection to panels, redundant via Dante™ network

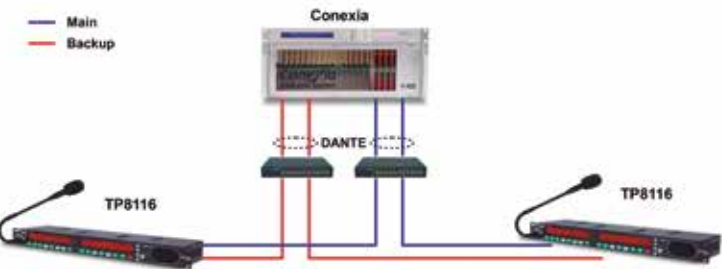

Dante™ protocol compatibility, offered in both our matrix and user panels, not only eases their connection and installation using IP networks, but also, for the very first time in an intercom system, allows for automatic redundancy of user panels communications at any point of the system.

**I/O INTERFACES AND DSP**

The ConeXia Intercom System is based on a broadcast audio matrix. This system offers the widest range of input / output interfaces. All the standard intercom system interfaces can be used. It's also possible to use every single audio format available in our system.



**BC2221**

The DSP card is designed to carry out the audio setting and routing. This card also allows us to make the system cross-points and perform processes of the system signals, such as: equalization, compressor-expander, VU-meters and delay. ConeXia allows the installation of up to 20 DSP cards.

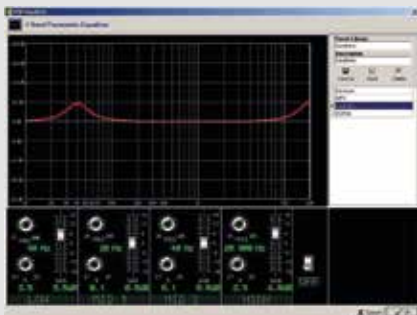

Equalizer



VU-meters



Delay

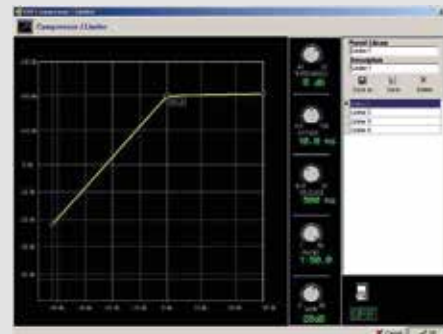

Compressor



**BC2240**

The Master Controller module allows the connection of 2 cards in mirror mode for redundancy. Ethernet connection is included to provide a system control cluster. This card also features GPIO.



**BC2213**

Optical Fiber Link module with 1,024 uncompressed audio channels. This allows the connection through optical fiber of several system frames or frames from other systems.



**BC2210**

Features a card for digital intercom slots. The AEQ-KROMA protocol allows the connection to intercom panels and all the previous features and accessories. It allows for the installation of up to 8 user panels per card.



**BC2224**

A DANTE™ – AES67 protocol multichannel AoIP card allows access to up to 64 audio channels. This card can be used to connect TP8000-series panels as well as any other DANTE™ – AES67 compatible device.



**BC2219**

VoIP multichannel audio card. Used to integrate XPLOERER wireless beltacks into the system. It provides up to 12 communication channels.



**BC2312**

AES10 MAD1 multichannel audio module with TX / RX coaxial and optical fiber connections for 56 or 64 channels with AES 11 synch or autosynch.



**BC2209**

Electronically-balanced analog input/output module with 20Hz-20kHz audio quality and 24 bit / 48kHz sampling. Provides 8 I/O slots.



**BC2202**

AES/EBU digital input / output module. Provides 4 stereo inputs/outputs with transformer insulation and the possibility of individual SPDIF audio setup. It also provides 4 GPIO slots.



**BC2203MH**

A module with 4 transformer-balanced inputs for microphones. Includes a Phantom power supply option and micro / line level mode selection. Also includes 4 headphone outputs.



## INTEGRATED AUDIOCODECS

### PHOENIX STRATOS

Dual Audiocodec with 2 IP, ISDN, and V-35 / X21 interfaces. Ethernet control from Conexia System. Features SmartRTP connection protocol and it is designed to fulfill with the N/ACIP EBU Tech 3326 requirement adding the OPUS encoding.



### PHOENIX VENUS 3

Dual Audiocodec for 2 IP interfaces. Ethernet control from Conexia System. Features SmartRTP connection protocol and it is designed to fulfill with the N/ACIP EBU Tech 3326 requirement adding the OPUS encoding and DANTE™.



### PHOENIX MERCURY

Single-channel IP Audiocodec. Ethernet control from Conexia System. Features SmartRTP plug-in protocol and is designed to comply with N/ACIP EBU Tech 3326, additionally providing OPUS encoding.



## DANTE™ / AES 67 I/O INTERFACES

### NETBOX 32

DANTE™ interface with 32 input / output channels. Plugin for 16 analog audio channels and 8 digital stereo pairs.



### NETBOX 8

DANTE™ interface with 8 input / output channels. Plugin for 4 analog audio channels and 2 digital stereo pairs.



### NETBOX 4

DANTE™ interface with 4 high-quality microphone inputs and headphone outputs.



This NETBOX interface range allows us convert any digital or analog audio within the system to the DANTE™ – AES67 standards and make them compatible with the equipment of more than 300 manufacturers.

# TP8000

Series TP8000 User Panels have been designed to achieve broadcast audio quality communications that Conexia and CrossNET are offering.

IP connectivity is included to provide an easy setup and a high-quality audio in DANTE™ format -compatible with AES-67 standard-.

Audio is digitized and processed with 48 kHz sampling frequency and 24 bits resolution, providing a 20 Hz to 20 kHz bandwidth with minimal distortion.

These series panels include a DSP that allows the audio digital processing in order to avoid the acoustic echo. Also adjust automatically the pitch of the voice and speech habits of each speaker. The acoustic has been designed to offer the best vocal comprehension and clarity of sound.

### EXPLANATION OF THE DSP FUNCTIONS

The TP8000 panels features built-in DSP providing the following audio processing:

- Echo cancelling to avoid local feedback and potential returns.
- 3-band parametric equalizer with high-pass and low-pass filters in order to adjust audio brightness and choose the best compromise between vocal comprehension and clarity of sound.

- Dynamics control:
  - Compression, for a wide range of distances and angles to the microphone.
  - Expander and noise gate, to eliminate or minimize room ambient noise.
- Generation and configuration of noise gate allowing us to provide sound to the user panel with the best possible listening environment for our communication.

The audio setup is managed through the “Crossmapper” software. There are standard user profiles provided by default, but it is possible to modify, adapt or create new ones with specific requirements.

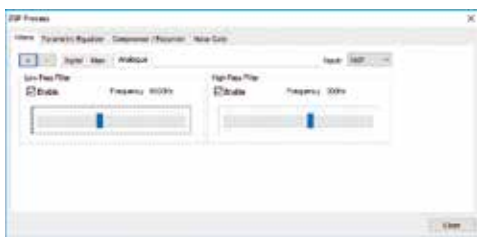

Filter adjustment



EQ adjustment



Compressor / Expander adjustment



Noise gate settings

### PANEL SLOTS AND PANEL CONNECTIONS SPECIFICATIONS

#### Connectivity

Series TP8000 panels features the following connection ports:

- Dual high-quality AoIP connection in Dante™ format allowing us to connect the panel to different systems or create redundancy of the system.
- Compressed VoIP audio connection offering low binary rate to allow for remote connections through the Internet public network.
- A digital audio port with private protocol making the panel compatible with previous KROMA systems.
- A high-quality analog input / output audio port, allowing for connection to any external system.

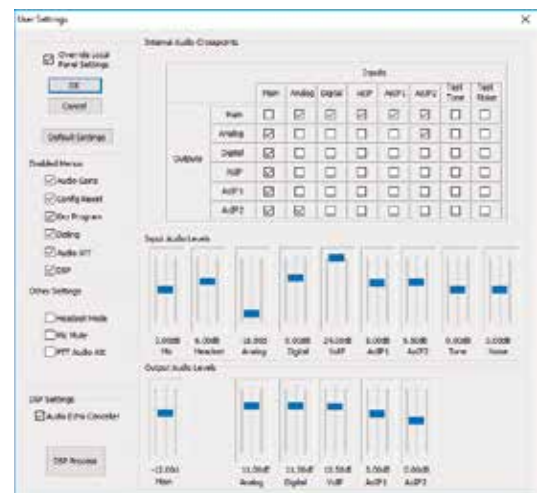



## TP8000

### TP8116

19" rack 1U user panel with 16 programmable keys organized in four different pages. This panel provides an individual volume control per each communication crosspoint, echo canceller and DSP. Features dual Dante™ AoIP, VoIP, as well as one analog and one digital audio port. All the info is shown in a graphic display with up to two text lines per key, plus a third line indicating the crosspoint's audio level.



### EP8116

19" rack 1U extension panel with 16 programmable keys organized in 4 different pages. This panel provides a numeric keypad for an easy calling management between the system phone interfaces. Also features a loop input / output that allows the connection of up to three extension panels to the same user panel.



### TP8416

Desktop user panel with 16 programmable keys, organized in four different pages. This panel provides an individual volume control per each communication crosspoint, echo canceller and DSP. Features dual Dante™ AoIP, VoIP, as well as one analog and one digital audio port. Information is presented in a graphic display with up to two text lines per key plus a third line indicating the crosspoint's audio level.

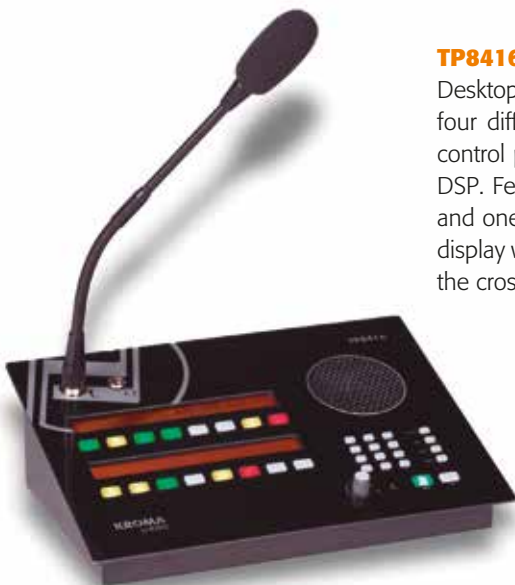

# OLYMPIA 3

## OLYMPIA 3 COMMENTARY UNIT



**Operates as an Intercom Panel and a Commentary Unit at the same time**

**Olympia 3** represents a breakthrough in the development of this kind of systems, as it can operate standalone or for example in a mobile unit and integrated with an Intercom System. Even if in essence it is a Commentary Unit, it can operate as an Intercom Panel.

The OLYMPIA 3 can be operated in a hybrid mode, having two simultaneous functions:

An Intercom User Panel:

- For this mode, the channel "COMMENTATOR 1" includes the required functionality and signaling to be able to operate as an Intercom channel. When operating as an intercom panel it provides the same level of functionality as the KROMA by AEQ series-8000 user panels.

Commentator 1 channel assumes the functions of an intercom panel. The display corresponding to channel 1 will adopt the "Intercom mode" and the keys will adopt the programmed intercom destinations or functions and the associate microphone and headphone will form part of the Intercom System.

A Commentary Unit:

- The OLYMPIA 3 CU CONTROL application configures and controls the CU except the circuit that Commentator 1 is using as its intercom circuit and when operating in this Intercom mode.

### Outstanding features:

- Standalone commentary unit (CU), or AoIP connected with 8 channels via Dante™ protocol. Scalable architecture: simple routing to Dante™ IP devices; integrated in IP Intercom System, or connected to IP Commentary System Matrix.
- Standalone mono or stereo sound mixer with mixing, routing, tone and dynamics control. 3 commentator inputs and a dual-mono or stereo line level input. Listening of 8 remote and 2 local sources.
- Operates as an Intercom Panel at the same time as a Commentary Unit.
- Configurable as interpreter desk up to three languages.
- 3 1Gigabit IP ports per unit for redundancy, daisy chain and auxiliary data or video transport.
- Dual power supply: 48 VDC via PoE or external local power supply.
- Software Configuration and remote control.
- Rugged and ergonomic mechanics, suitable for indoors and outdoors locations.



# EasyNET

## YOUR PARTY-LINE COMMUNICATIONS SOLUTION WITHOUT THE NEED FOR A MATRIX

### EasyNET System Diagram

EasyNET is a low bitrate, VoIP based, Party-Line System with 4 independent channels that allows you to connect your panels in any already existing network infrastructure, or even using the public Internet for remote connections. It doesn't require a matrix to make cross-points. The system consists in three types of user panels: rack-mount, desktop and beltpack.

This is one of the easiest to configure systems available in the market. Its installation only requires the connection of all the (up to 28) user panels to the same Ethernet network.

All three terminals feature 4 keys to connect to any of the 4 available audio channels; this advanced functionality is similar to what a matrix-based system offers and provides great operation flexibility.

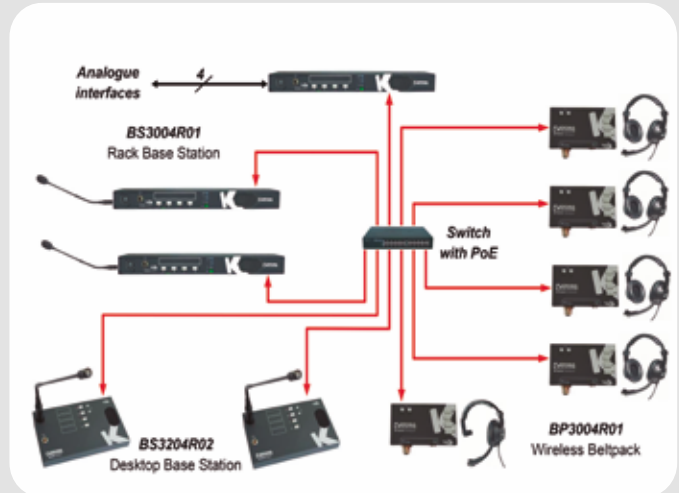

### Three different terminals to cover every need.

**BS3004** is a rack-mount terminal with 4 keys, integrated loudspeaker and optional microphone and headphone. It also includes 4 analog four-wire ports with gain control that can be used to integrate external audio sources in the system, such as camera audio feeds, etc.



**BS3204** is a desktop terminal with 4 keys, integrated loudspeaker and optional microphone and headphone. It also includes 4 analog four-wire ports with gain control that can be used to integrate external audio sources in the system, such as camera audio, etc.

**BP3004** is a wired beltpack with 4 keys and gain control. It is lightweight and compact and can be powered by PoE (Power over Ethernet), so only one connection is required.



### KROMA BY AEQ INTERCOM SYSTEMS

MORE THAN AN INTERCOM: A Global Solution for Audio, Communications and Intercom

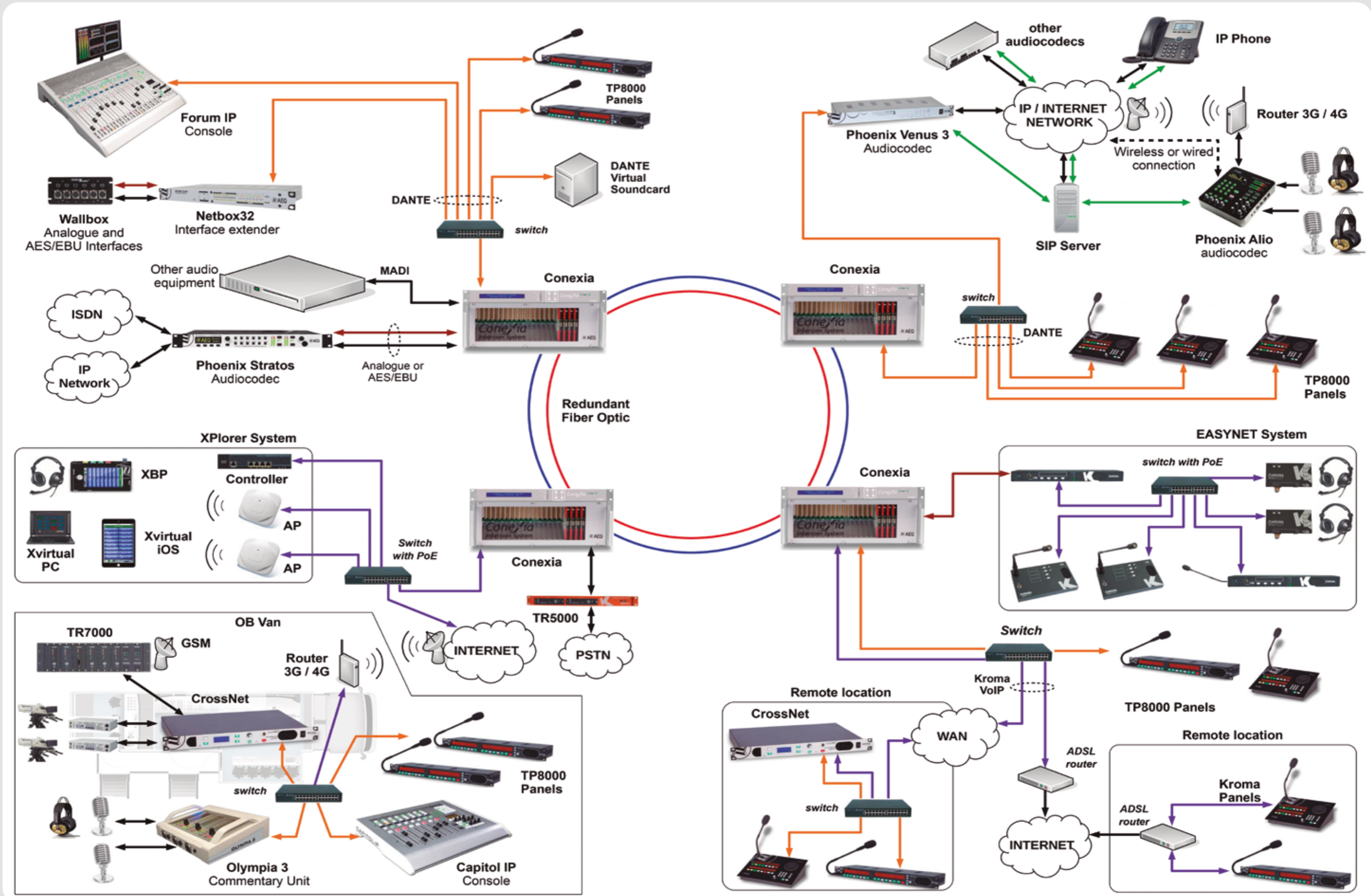



**Xplorer** is the perfect combination for your Intercom System. It is a communications system based on Xvirtual, an application for iOS and Windows devices with the same functionality that can be found in an Intercom Panel.

The application can be installed on a PC turning it into a User Panel and part of your Intercom System, only requiring a simple Ethernet connection.

In the same way, it can turn any Apple iPhone, iPod or iPad device into a Wireless Intercom Panel.

Just connect it to a Wi-Fi network providing access to a Conexia or Crossnet Intercom System to build your Wireless Beltpack System.

Taking full advantage of what this technology provides, a dedicated hardware terminal has been designed and becomes an advanced Beltpack with features you couldn't find before in any existing wireless terminal.



### Xbp Panel

Xbp is a hardware intercom panel based on 5GHz WiFi technology. It combines the engine of the Xplorer application management with the processing and connectivity of an Apple iPod with iOS.

It features 4 physical keys that provide quick access to the 16 possible communication channels that are displayed on the main screen. It features volume and mute controls as well as an indicator showing the charge status of the booster battery.

## Technical Specifications

### Xvirtual Application

Operating system: Windows or iOS.  
 16-key intercom panel, 4 assignable to Xbp physical Keys.  
 Mute Function.  
 Supports external physical panel Bluetooth connection in the iOS Version.  
 Compatible with all KROMA Digital Intercom Systems.  
 Enhanced audio quality with G722 algorithm. when operating with CONEXIA Intercom Systems.

Key functions: key functions for multiple operating modes have been defined:

- Talk.
- Listen.
- Talk & Listen.
- Remote One Way: Unidirectional remote cross-point.
- Remote Both Ways: Bidirectional remote cross point.
- Remote Volume: Vary the audio level of any cross point between an input and an output.
- Dial Call: Controls phone call.
- GP Out: Remote activation of the Tally or GPO output.
- Hot Key: Hot-reprogrammable key from LiveCrossmapper.
- Reply: Call reply keys from non pre-configured ports.

LED Colour and flash signaling coding:

- Blue: Idle state.
- Green: Command executed.
- Red: Channel established.
- Flashing green: Calling.
- Flashing red: Incoming call.
- Amber: Command executed + audio established.

### Xbp Panel

- Digital wireless connection using Wi-Fi network.
- Compatible with 802.11 b/g/n networks using the 2.4 GHz band and 802.11a/n using the 5 GHz band.
- Gain control (digital rotary encoder).
- Mute function.
- Sixteen configurable virtual keys.
- Four configurable physical keys.
- Headset professional connection and earphone amplifier
- Integrated antenna.
- Basic autonomy: around 12 hours, depending on conditions of usage.
- Power bank autonomy: around 13 extra hours.
- Dimensions (length x width x height): 141 x 24 x 70 mm
- Power bank autonomy: around 13 extra hours.
- Dimensions with cover and power bank (length x width x height): 147 x 36 x 76 mm.
- Weight: 360g (with power bank 452 g).

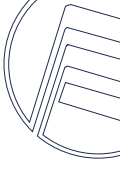

WiFi 5G technology allows for operation of this kind of systems in any environment, as it works in a free and non-saturated frequency band. Installation and system power up is really easy since this technology is well-known and already implemented in any of your installations. Reusing your existing wireless network is possible, only having to ensure that the QoS is guaranteed.

Nowadays, WiFi systems including managed access points provide "roaming" functionality, offering wide, seamless coverage within the entire network. This provides flexibility in production its and resource requirements without the need to reconfigure devices or pair every Beltpack to the different antennas, which becomes tedious.

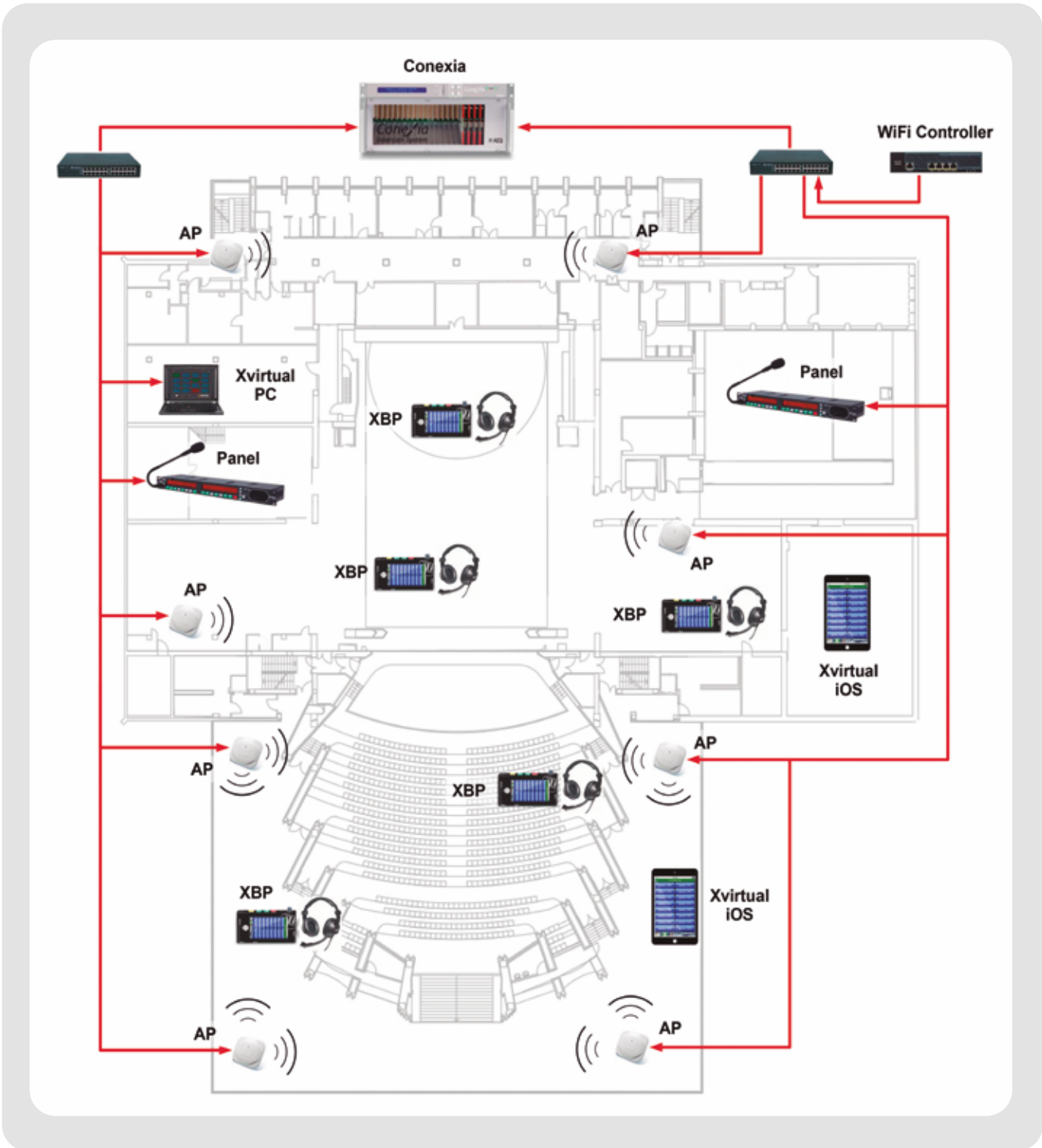



# CROSSMAPPER

All AEQ-Kroma Intercom systems use a CrossMapper software for the setup. This software provides a user-friendly graphical interface and also offers a powerful setup capabilities, allowing total access to the setup, care and control of the system.

### User panels and DSP configuration

The user has an easy access to the setup for each intercom panel, with individual setup options for each key. Additional features such as groups management, conferences, telephone dialing, IFB's, etc are included. It is also possible to access to the I/O matrix internal set up for the different ports in each panel and adjust their input and output levels. The TP8000-series offers an internal setup for the DSP.

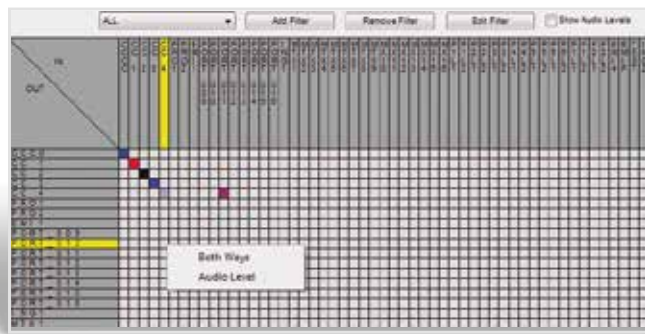
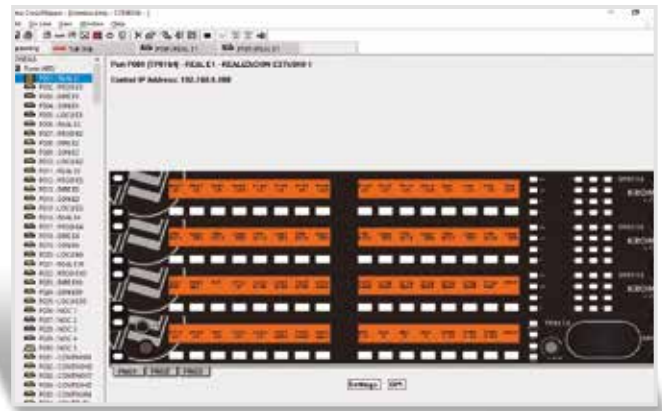

### Crosspoints and audio levels

If we are connected online to the matrix, we can currently see all the established audio connections in the system on the spot. The "Crosspoint" menu allows us to make connections on-the-go. The same menu allows the adjustment of the audio level for each existing crosspoint and to see any possible change made by the users. It is possible to edit the different views to filter the users according to the particular needs.

### Call management

AEQ-Kroma Intercom systems offer a huge range telephone interfaces: analog, ISDN, GSM, etc. CrossMapper can manage the dialed and received calls like in a phone PBX, able to identify, route or reject the calls. This will make the management of all our communications during operation much easier.

### IFBs and Groups

The system offers several IFB possibilities, such as a complete audio interruption or different attenuation levels. All these options are implemented in the matrix. The setup of any IFB can be used with any device connected to the system.

It is also possible to generate groups so every software-created programming can be applied on all the group components at the same time.

### System Status

The CrossMapper is the perfect tool to control our matrix status and all the terminals and interfaces connected to the system. Using the System Status online menu, we can check currently the complete status of each connected component, as well as it's additional information. This grants us absolute remote control on the intercom system from any location.

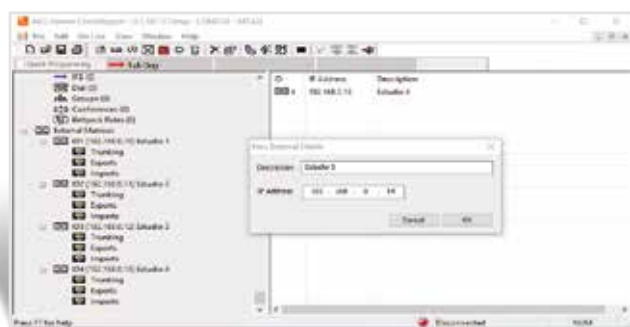
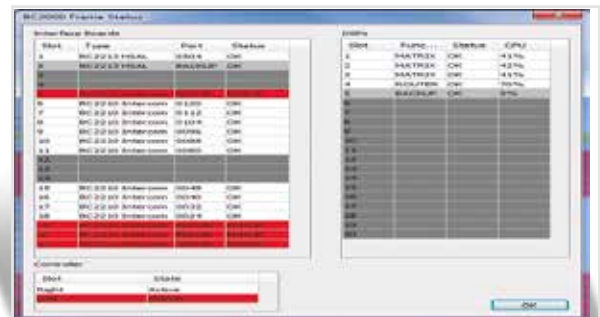

### Non-blocking Trunking

Our systems are able to connect to each other, building up larger systems where every user can have access to the rest of the systems without any limitation or restriction. The Trunking menu included in the software setup allows us to check and configure cross-points with any of the terminals and interfaces in the others Intercom matrices.

# LIVE CROSSMAPPER

## Live CrossMapper: Dynamic operation

Productions are getting more and more dynamic, so we need the proper tools to stay tuned.

Live CrossMapper is a multi-user tool that enable an easy online management of the matrix, allowing the reconfiguration of the intercom panels' keyboard without any influence for the rest of users that don't requite constantly setup changes.

## XPT Manager

It is impossible to foresee all the possible situations. That's why Live CrossMapper offers an easy, quick and user-friendly way to make online crosspoints between any panels or interfaces within our system. A simple mouse click will generate a new crosspoint.

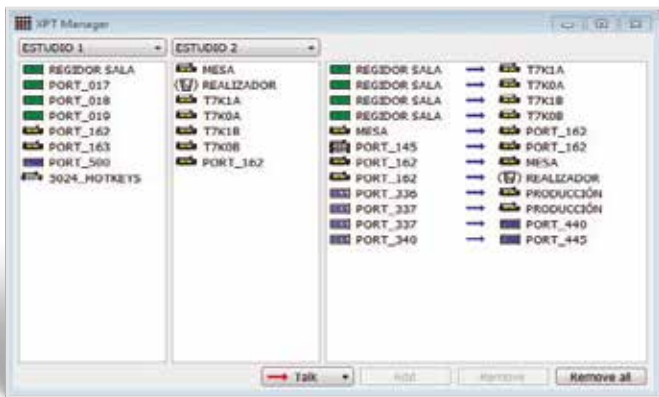

## XPT Viewer

A fast and easy way to check the summary of the communications established with our matrix. A complete listing of our panels, the currently established cross-points, their setup and the audio levels currently programmed or modified. In essence, this tool provides a full control of our communications in a single screen.

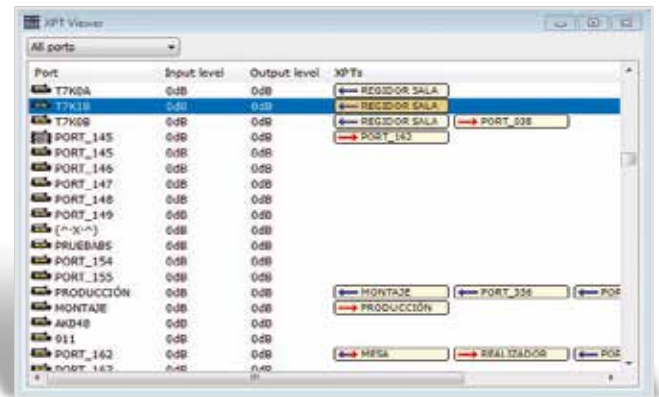

## HotKeys

Intercom panels are no longer static: communications changing their destinations, live contribution changes... They need different setups in the same production, without affecting the rest of the panels. That's why we created reconfigurable hotkeys that allows us to quickly change assignments and tasks.

## IFBs

The number of coordination circuits, generation of N-1 circuits, and management of return feeds always makes a setup operation complicated. Live Crossmapper turns into an essential tool as it provides a special screen for their management, that can be performed with just two mouse clicks.

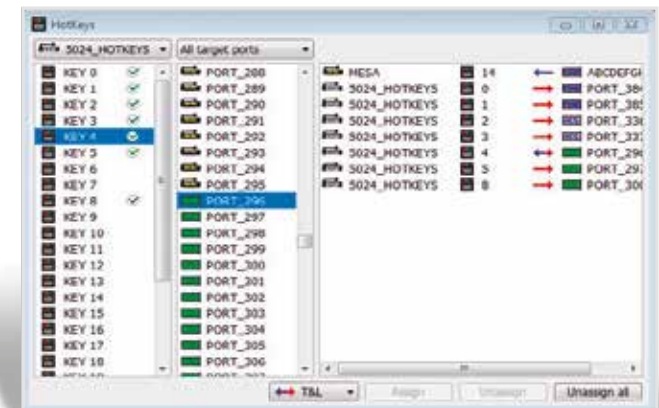
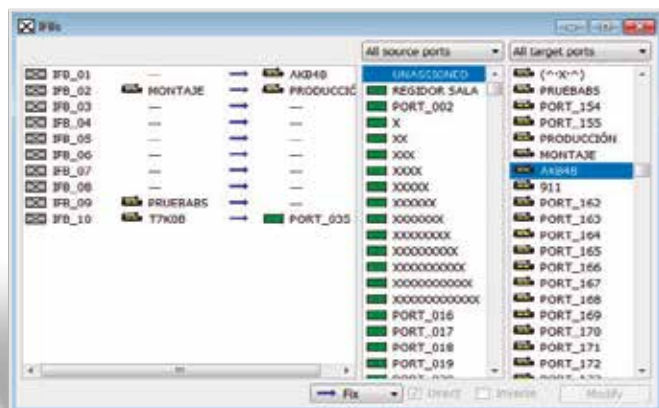





**AEQ - USA**

Phone: +1 (954) 581 79 99

e-mail: sales@aeqbroadcast.com

**AEQ - KROMA MÉXICO**

Phone: +5554132716

e-mail: creyna@aeq.es

**INTERNATIONAL SALES**

Margarita Salas, 24 · 28919 · Leganés · Madrid · Spain

Phone: +34 91 686 13 00 · Fax: +34 91 686 44 92

e-mail: aeqsales@aeq.es · website: www.aeq.eu